

Developing Smart Workspace Based IoT with Artificial Intelligence Using Telegram Chatbot

Muhamad Muslih, Somantri, Dedi Supardi, Elpid Multipl, Yusup Maulana Nyaman, Aditya Rismawan, Gunawansyah
Departement of Infomatics Engineering

Nusa Putra University

Sukabumi, Indonesia

muhamad.muslih@nusaputra.ac.id, somantri@nusaputra.ac.id, dedi.supardi@nusaputra.ac.id, elpid.multipl@nusaputra.ac.id,
yusup.maulana@nusaputra.ac.id, aditya.rismawan@nusaputra.ac.id, gunawansyah@nusaputra.ac.id

Abstract— IoT (Internet of things) is a concept that aims to take advantage of connected internet connectivity continuously, some IoT capabilities include data sharing, remote control and so on, one of the uses that can be used is by controlling several electronic devices on the workspace via the internet, such as lamp, fan, drawer lock, electrical outlet, and temperature check. This research was carried out by building a remote control device with Esp 8266 to access local control with the help of Artificial Intelligence Chatbot by using Telegram Messenger. This test is done to make it easier for employees to control electronic devices on their workspace through smartphones or PCs, without having to manually switch and support energy efficiency in saving electricity. With Smart Workspace, it can make it easier for employees to control several electronic devices in their workspace without having to go back to the office to turn off or turn on the lights.

Keyword — *Internet of Things (IoT), Artificial Intelligence, Smart workspace, Chatbot, Telegram, ESP 8266.*

I. INTRODUCTION

IoT (Internet of things) is a concept in which internet connectivity can connect and exchange information with devices around us such as lights, fans, curtains etc. That makes it possible to be controlled, monitored or accessed remotely, making it easier for users to use it without having to touch it physically.

Internet of Thing (IoT) is a concept where an object has the ability to transfer data over a network without requiring human to human or human interaction to a computer. IoT has evolved from the convergence of wireless technology, micro-electromechanical systems (MEMS), and the Internet.

Tiredness after work sometimes makes employees forget to turn off electronic devices at

their workspace so that electricity stays on and causes a waste of electrical energy.

By implementing the Internet of things on the workspace and the use of artificial intelligence can make it easier for employees to be more efficient in using electricity, time and energy because in this case the employee only needs a smartphone / PC / Notebook by connecting the internet to control all electronic devices in his workspace.

Telegram Messenger is an increasingly popular messaging app. more and more users are using it, there are 62 million users using telegram, with Daily Active Users (DAU) 15 million people and every week there are 1 million new users who sign-up on Telegram [1]. Telegram Messenger has been widely used in everyday life whether for business, colleagues, or family, because it is easier to access it either with or without a smartphone can still be opened through a web browser not just glued to smartphones.

With Smart Workspace, it is expected that it will be easier for employees to access electronic devices on their desks, by only giving orders from smartphones using telegram messengers as well as using Artificial Intelligence Chatbot provided in this study. Allows remote control of all electronic devices in workspace. The use of Chatbot is also used to remind employees through notifications if it allows the device to be turned on or off as well as giving notifications to employees to turn on the fan when the temperature is hot. In this case, Chatbot acts as an invisible office servant who serves the workplace like as secretary in the field of workplace control.

II. RELATED WORK

Research related to the concept of the Internet of things, including IoT which is used to control home appliances, especially electronic equipment remotely using an internet connection and

ATMEGA16 microcontroller [2], the development of systems in other research is connecting embedded ESP8266 system that functions as a control with real-time firebase a database that acts as a mobile Backend as a Service to store data [3], a remote temperature monitoring system that uses the MQTT protocol can be implemented using the local MQTT server and the global MQTT server. The use of the global MQTT server allows temperature access to come from anywhere, at any time and anywhere as long as there is an internet connection [4].

IoT system can be used for home detection and security from unexpected problems such as fire, thief, temperature condition and motion gesture [5]. The use of IoT concepts in use also in a Smart grid is a power system based on sensing technology, communication, digital control, information technology (IT) and other field equipment that serves to coordinate the existing processes in the power grid making it more effective and dynamic in its management. IoT can be used to monitor solar power generation (Photovoltaic Generation System) especially through the Wireless Sensor Network (WSN) [6].

In the agriculture sector, the use of IoT was also developed to detect potential agricultural land to determine suitable plants using Raspberry-Pi [7]. And in the health sector, IoT is used to monitor Heart Rate [8].

The use of ESP 8266 is an easy and inexpensive Internet of Things (IoT) key to use to make a system that will make it easier for humans to control electronics around it [9], such as Wireless Home Appliance Control using IoT [10], Smart Door Locks development using Mobile Backend as a Service [11] and the development of home automation and smart security systems based Low-Cost Real-Time [12,13].

III. DESIGN OVERVIEW

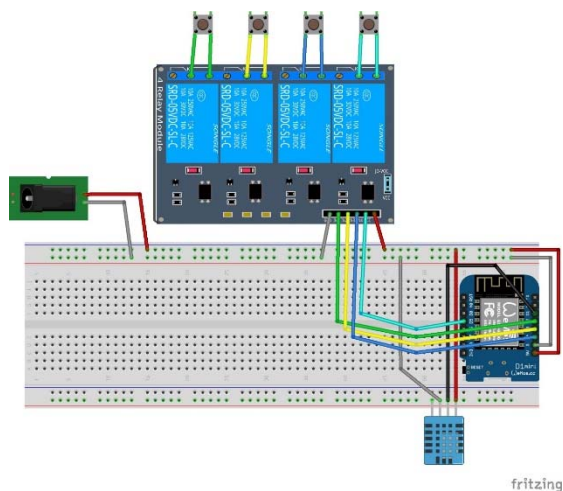

Fig. 1. System Connection

The ESP8266 is a low-cost WIFI microchip with a self-contained System-On-Chip (SOC) with integrated TCP/IP protocol stack that can give any microcontroller access to WiFi network and can be programmed using Arduino IDE.

The ESP8266 enabled WiFi module is used for wireless communication and ON/OFF switching of the relay using its built-in IO pins. It is used to connect with our mobile devices to turn off or turn on some devices by using some application messenger service.

There are many internet messenger applications that support API and of course free license. Applications are selected is Telegram because of several factors that support such as for example can be used on pc without a smartphone always on.

Telegram messenger also has many applications developed through its API by utilizing BOT telegram. The process of making a telegram chatbot:

1. Create a new Telegram bot using the Bot Father.
2. Give the Telegram bot a friendly name with a unique username.
3. When the user has completed these steps, the bot will be successfully configured to communicate with users in Telegram.

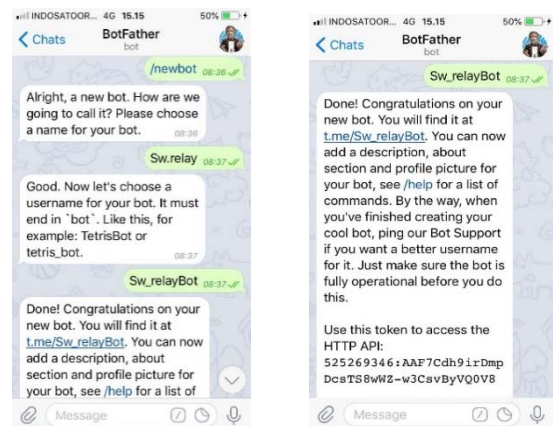

Fig 2. Making Telegram chatbot.

The following describes the steps of the flowchart or the overall program flow:

1. When starting, conduct the process of program initiation.
2. The program runs in a standby mode position waiting for a message from the user
3. If the message is incorrect then the program will send a notification message to the user.
4. If the message from the user is correct, the program will identify the message.
5. If the user's message is directed to the lamp, then the program will turn on or turn off the lamp based on the message sent. Through a particular GPIO port that is connected to the relay. And then the program will send a notification to the user that the lamp is on or off.
6. If the message is not for the lamp, the program will identify the user's message for controlling

the fan, drawer lock, electrical outlet, or temperature check?

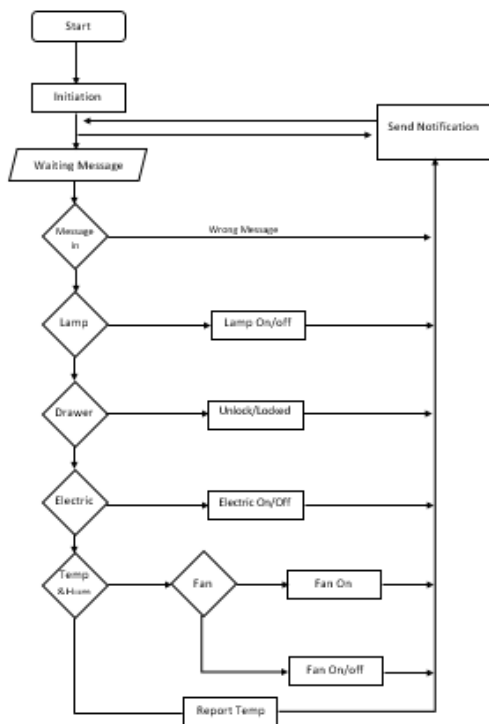

Fig. 3. Development groove software Message

7. If the user's message is directed to the fan, the program will turn on or turn off the fan, the message sent via the GPIO port and sent to the relay. and the program will send a notification to the user that the fan is already on or off.
8. If the message is not for the lamp and the fan, the program will identify the user's message for controlling drawer lock, electrical outlet, or temperature check?
9. If the user's message for drawer lock, the program will lock and unlock the drawer, the message sends via GPIO port and sent to the relay, the program will send a notification to the user that the drawer already locks or unlock.
10. If the message is not for the lamp, the fan, or drawer lock, the program will identify target the user's message for controlling electrical outlet, or temperature check?
11. If the user's message for the electrical outlet, the program will turn on or turn off the electrical outlet, the message send via GPIO port and sent to the relay, the program will send a notification to the user that the electrical outlet is already on or off
12. If the message is not for the lamp, the fan, drawer lock, and electrical outlet the program will identify user's message or temperature check.
13. If the user's message for the temperature check, the program will send temperature data

obtained from DHT11 which is connected to ESP8266.

14. If the temperature exceeds 37°C then the program will send a notification that the temperature is very hot and recommend to turn on the fan to the user
15. If not all, the program sends a notification message to the user that the message sent is incorrect.

IV. RESULT AND DISCUSSION

This test aims to find out the programs and devices that are used can work properly as expected.

The ESP8266 as a central controller, it is programmed to be connected to an access point in the workspace environment and has internet access.

Testing is done by the user sending messages to the telegram bot using a smartphone, the user sends the command/message correctly and incorrectly. Then observe whether the program and the device are running according to its command either to turn on or turn off some of the devices that are in the workspace and make sure the notification is received by the user.



Fig. 4. Implementation and testing the device

In testing smart workspace through telegram messages is given some instructions to control the output to be on / off.

The following commands are used:

1. Lamp on - to turn on the lamp
2. Lamp off - to turn off the lamp
3. Fan on - to turn on the fan
4. Fan off - to turn off the fan
5. Lock on – to lock the drawer
6. Lock off – to unlock the drawer
7. Electric on – to turn on the electrical outlet
8. Electric off – to turn off the electrical outlet

If the user sends an incorrect message then the system will assume the command is wrong and sends a notification message to the user that the command is incorrect. If the user sends a correct

message, the system will send a notification message to the user that those devices (lamp, fan, drawer lock or electrical outlet) already on or off, lock or unlock.



Fig.5. display message commands via telegram



Fig. 6. Testing the devices with ON command



Fig. 7. Display Fan with ON command



Fig. 8. Display Drawer lock with unlock command

V. CONCLUSION

With the smart workspace, the workers can control the device around the workplace, in order to reduce waste of electricity. For the next development is expected to develop and create a better system with the addition of more and varied output to facilitate more optimization in controlling other devices that are around the workplace and also it can be developed with a database system in each smart workspace of each worker.

REFERENCE

- [1] A. Dogtiev, Telegram Revenue and Usage Statistics, <http://www.businessofapps.com/data/telegram-statistics/>. Accessed on 23 Sept 2018.
- [2] T. Medi and Y. Muhammad, "Design Simulation of Intelligent Home Based Microcontroller ATMEGA16". Faculty of Computer Science and Electronics. Universitas Gajah Mada, 2014.
- [3] M. I. Mahali, "Smart Door Locks based on Internet of Things concept with Mobile Backend as a Services", Faculty of Electronic Engineering and Informatics. UNY, 2016.
- [4] T. Budioko, "Internet-Based Remote Monitoring System Of Things Using the MQTT Protocol". Faculty of Computer Engineering. STMIK AKAKOM Yogyakarta, 2016.
- [5] Arie Marvin and Eka P Widiyanto, "Home security system based on Internet of Things (IoT) with Raspberry Pi", Technical Information. STMIK GI MDP Palembang.
- [6] Nur Asyik H and Dirvi Eko J S, "Design and Application of Internet of Things (IoT) for smart grid power system". Electrical Engineering and Computer control, Politeknik Negeri Madiun, 2017.
- [7] Junfitrhana, Anggy Pradiftha, et.al "Developing potential agriculture land detector for determine suitable plant using Raspberry-Pi". International Journal for Computing, Engineering, and Design (ICCED). 2017.

- [8] Suresh K N, Nandha K, et. al. "*Heart Rate Monitoring System Using IoT* " IJSRD - International Journal for Scientific Research & Development| Vol. 5, Issue 02, 2017.
- [9] Manan Mehta, "*Esp 8266: A Breakthrough in wireless Sensor Networks and internet of things*", ARK Techno solutions, Mumbai, India, 2015.
- [10] Govid P Arya, Aliya M, and Suryakant G, "*Wireless Home Appliance Control using IoT*" International Journal of Computer Applications (0975 – 8887) Volume 168-No.2, 2017.
- [11] M Izzudin Mahali, "*Smart Door Locks based on Internet of Things Concept with Mobile Backend as a Service*" Jurnal Electronics, Informatics, and Vocational Education (ELINVO), Volume 1, Nomor 3, 2016.
- [12] Mantoro, T., Ayu M.A., Elbara, Mobile Web-enabled in Smarthome Wireless Node Infrastructure, Proceedings of the 9th International Conference on Advances in Mobile Computing & Multimedia (MoMM-2011), Ho Chi Minh, Vietnam, 5-7 December 2011.
- [13] Kishore P, Veeramanikandasamy, "*Internet of things based Low-Cost Real-Time Home Automation and Smart Security System*" International Journal of Advanced Research in Computer and Communication Engineering Vol 6 Issue 4, 2017.